



MURS405 THRU MURS460

Reverse Voltage - 50 to 600 Volts Forward Current - 4.0 Ampere

SURFACE MOUNT SUPER FAST RECOVERY RECTIFIER

Features

- ◆ The plastic package carries Underwriters Laboratory Flammability Classification 94V-0
- ◆ For surface mounted applications
- ◆ Metal silicon junction, majority carrier conduction
- ◆ Low power leakage
- ◆ Built-in strain relief, ideal for automated placement
- ◆ High forward surge current capability
- ◆ High temperature soldering guaranteed: 250 °C/10 seconds at terminals

DO-214AB/SMC **RoHS COMPLIANT**

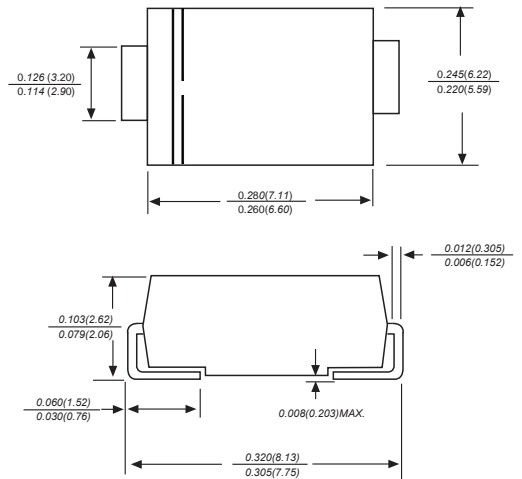

Dimensions in inches and (millimeters)

Mechanical Data

Case: JEDEC DO-214AB/SMC molded plastic body
 Terminals: Solderable per MIL-STD-750, Method 2026
 Polarity: Color band denotes cathode end Mounting
 Position: Any
 Weight: 0.007 ounce, 0.25 grams

Maximum Ratings And Electrical Characteristics

Ratings at 25 °C ambient temperature unless otherwise specified.

Single phase half-wave 60Hz, resistive or inductive load, for capacitive load current derate by 20%.

Parameter	SYMBOLS	MDD MURS405	MDD MURS410	MDD MURS415	MDD MURS420	MDD MURS430	MDD MURS440	MDD MURS450	MDD MURS460	UNITS
Marking Code										
Maximum repetitive peak reverse voltage	V_{RRM}	50	100	150	200	300	400	500	600	V
Maximum RMS voltage	V_{RMS}	35	70	105	140	210	280	350	420	V
Maximum DC blocking voltage	V_{DC}	50	100	150	200	300	400	500	600	V
Maximum average forward rectified current at TL (see fig.1)	$I_{(AV)}$	4.0								A
Peak forward surge current 8.3ms single half sine-wave superimposed on rated load (JEDEC Method)	I_{FSM}	125								A
Maximum instantaneous forward voltage at 4.0A	V_F	0.89				1.28				V
Maximum DC reverse current at rated DC blocking voltage $T_A=25^{\circ}C$ $T_A=125^{\circ}C$	I_R	10.0 100								mA
Typical junction capacitance (NOTE 1)	C_J	95								pF
Typical thermal resistance (NOTE 2)	$R_{\theta JA}$	20.0								$^{\circ}C/W$
Operating junction temperature range (NOTE 3)	t_{rr}	25.0				50.0				ns
Storage temperature range	$T_j T_{STG}$	-55 to +150								$^{\circ}C$

NOTE: 1. Thermal resistance from junction to ambient.
 2. Measured at 1.0MHz and applied reverse voltage of 4.0V DC.
 3. 1. Measured with $I_F=0.5A$, $I_R=1A$, $I_{rr}=0.25A$.



MURS405 THRU MURS460

Reverse Voltage - 50 to 600 Volts Forward Current - 4.0 Ampere

Typical Characteristics

FIG.1 – TEST CIRCUIT DIAGRAM AND REVERSE RECOVERY TIME CHARACTERISTIC

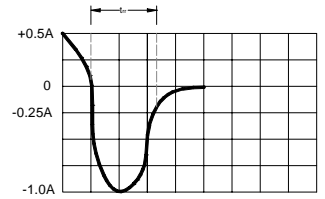
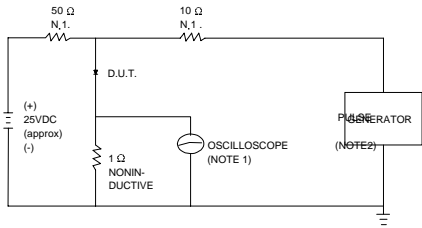

NOTES:1.RISE TIME = 7ns MAX.INPUT IMPEDANCE = 1M . 22pF.
2.RISE TIME = 10ns MAX.SOURCE IMPEDANCE = 50 . Ω

SET BASE FOR 10/20 ns/cm
TIME

FIG.3 – TYPICAL REVERSE CHARACTERISTIC

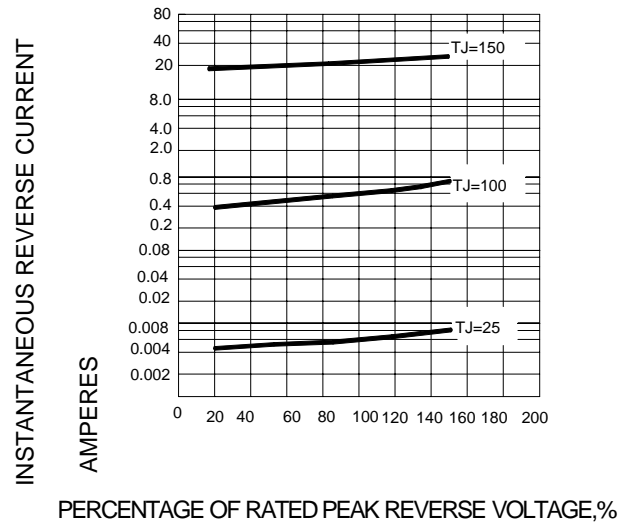
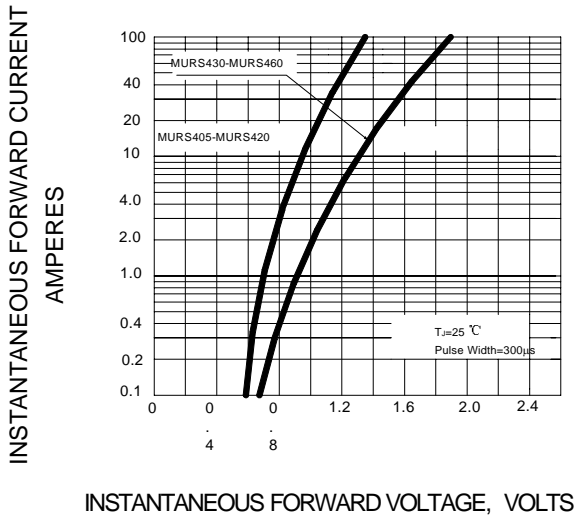

FIG.4 – TYPICAL JUNCTION CAPACITANCE

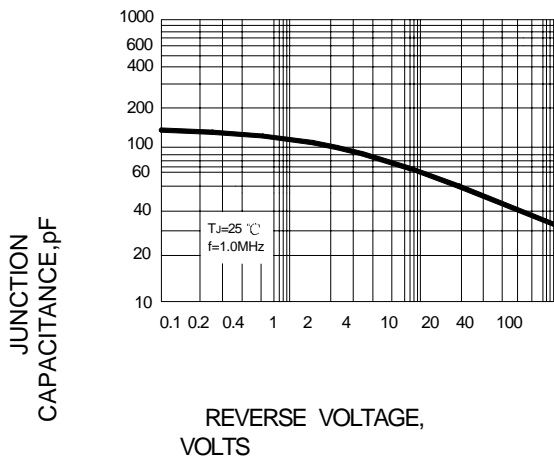
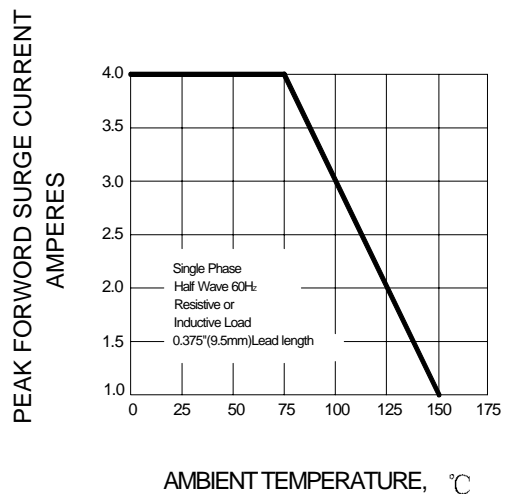

FIG.5-FORWARD DERATING CURVE



The curve above is for reference only.



MURS405 THRU MURS460

Reverse Voltage - 50 to 600 Volts Forward Current - 4.0 Ampere

Packing information

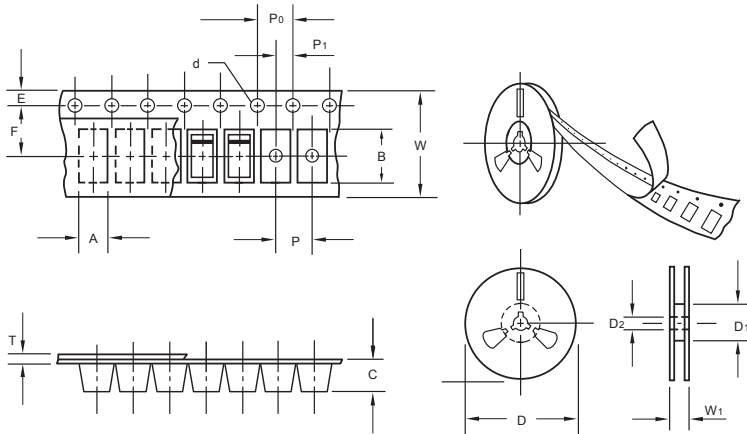

unit:mm

Item	Symbol	Tolerance	SMC
Carrier width	A	0.1	6.15
Carrier length	B	0.1	8.41
Carrier depth	C	0.1	2.42
Sprocket hole	d	0.05	1.50
13" Reel outside diameter	D	2.0	330.00
13" Reel inner diameter	D ₁	min	50.00
Feed hole diameter	D ₂	0.5	13.00
Sprocket hole position	E	0.1	1.75
Punch hole position	F	0.1	7.50
Punch hole pitch	P	0.1	8.00
Sprocket hole pitch	P ₀	0.1	4.00
Embossment center	P ₁	0.1	2.00
Overall tape thickness	T	0.1	0.25
Tape width	W	0.3	16.00
Reel width	W ₁	1.0	16.50

Note: Devices are packed in accordance with EIA standard RS-481-A and specifications listed above.

Reel packing

PACKAGE	REEL SIZE	REEL (pcs)	COMPONENT SPACING (mm)	BOX (pcs)	INNER BOX (mm)	REEL DIA. (mm)	CARTON SIZE (mm)	CARTON (pcs)	APPROX. GROSS WEIGHT (kg)
SMC	13"	3,000	4.0	6000	190*190*41	330	365*365*340	42000	14.0

Suggested Pad Layout

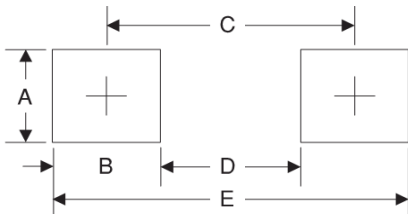

Symbol	Unit (mm)	Unit (inch)
A	4.3	0.170
B	4.1	0.160
C	7.9	0.311
D	3.8	0.150
E	12	0.472