



# DSL12 THRU DSL16

Reverse Voltage - 20 to 60 Volts Forward Current - 1.0 Ampere

## SURFACE MOUNT SCHOTTKY BARRIER RECTIFIER

### Features

- ◆ The plastic package carries Underwriters Laboratory Flammability Classification 94V-0
- ◆ For surface mounted applications
- ◆ Metal silicon junction, majority carrier conduction
- ◆ Low power loss, high efficiency
- ◆ Built-in strain relief, ideal for automated placement
- ◆ High forward surge current capability
- ◆ High temperature soldering guaranteed:  
250 °C/10 seconds at terminals

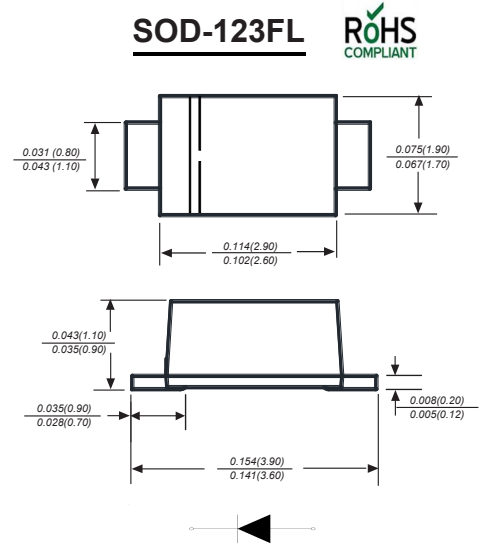

### Mechanical Data

Case: JEDEC SOD-123FL molded plastic body  
 Terminals: Solderable per MIL-STD-750, Method 2026  
 Polarity: Color band denotes cathode end  
 Mounting Position: Any  
 Weight: 0.0007 ounce, 0.02 grams

### Maximum Ratings And Electrical Characteristics

Ratings at 25°C ambient temperature unless otherwise specified.

Single phase half-wave 60Hz, resistive or inductive load, for capacitive load current derate by 20%.

Parameter	SYMBOLS	DSL12	DSL14	DSL16	UNITS
		D12	D14	D16	
Marking Code		D12	D14	D16	
Maximum repetitive peak reverse voltage	$V_{RRM}$	20	40	60	V
Maximum RMS voltage	$V_{RMS}$	14	28	42	V
Maximum DC blocking voltage	$V_{DC}$	20	40	60	V
Maximum average forward rectified current at	$I_{(AV)}$	1.0			A
Peak forward surge current, 8.3ms single half sine-wave superimposed on rated load (JEDEC Method)	$I_{FSM}$	30			A
Maximum instantaneous forward voltage at 1.0A	$V_F$	0.45		0.50	V
Maximum DC reverse current at rated DC blocking voltage	$I_R$	0.3 10.0	0.2 5.0		mA
Typical junction capacitance (NOTE 1)	$C_J$	180		80	pF
Typical thermal resistance (NOTE 2)	$R_{\theta JA}$	90			°C/W
Operating junction temperature range	$T_J$	-55 to +125			°C
Storage temperature range	$T_{STG}$	-55 to +150			°C

Note: 1. Measured at 1MHz and applied reverse voltage of 4.0V D.C.

2. PCB mounted on 2.0\*2.0" (5.0\*5.0mm) copper pad area.



## Typical Characteristics

Fig.1 Forward Current Derating Curve

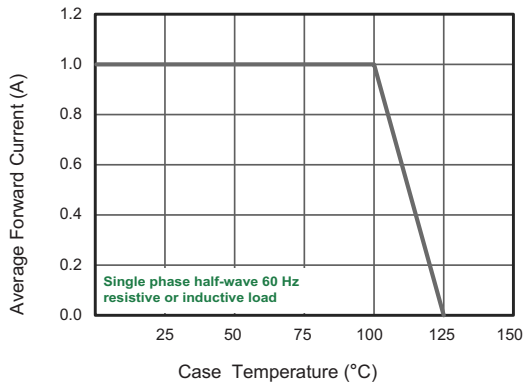

Fig.2 Typical Reverse Characteristics

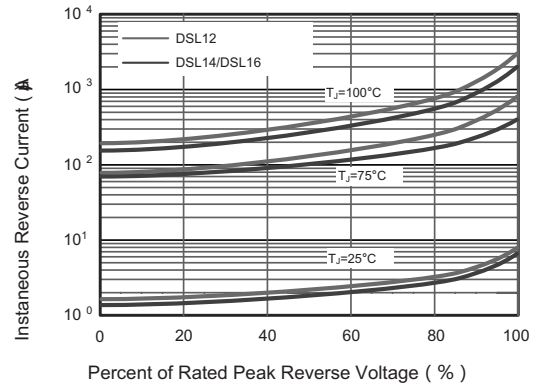

Fig.3 Typical Forward Characteristic

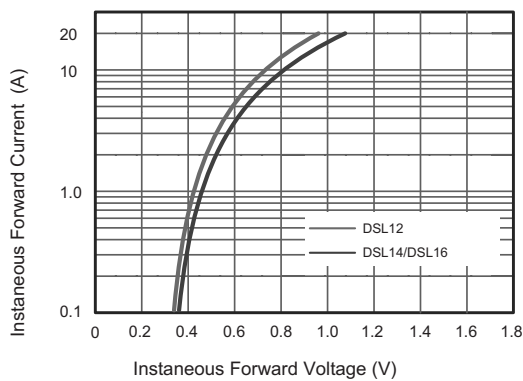

Fig.4 Typical Junction Capacitance

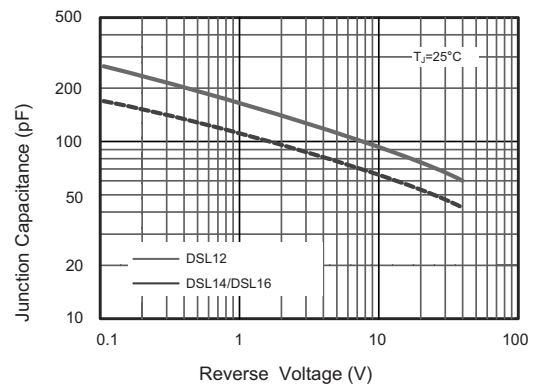

Fig.5 Maximum Non-Repetitive Peak Forward Surge Current

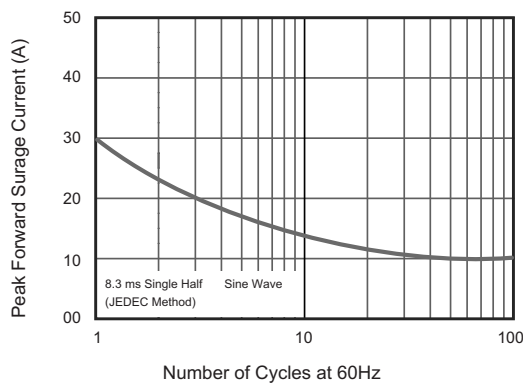
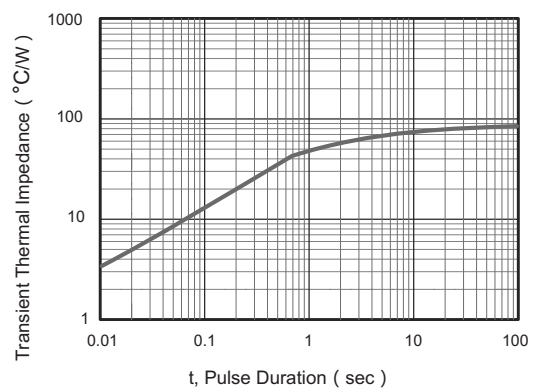

Fig.6 Typical Transient Thermal Impedance



The curve above is for reference only.



# DSL12 THRU DSL16

Reverse Voltage - 20 to 60 Volts Forward Current - 1.0 Ampere

## Packing information

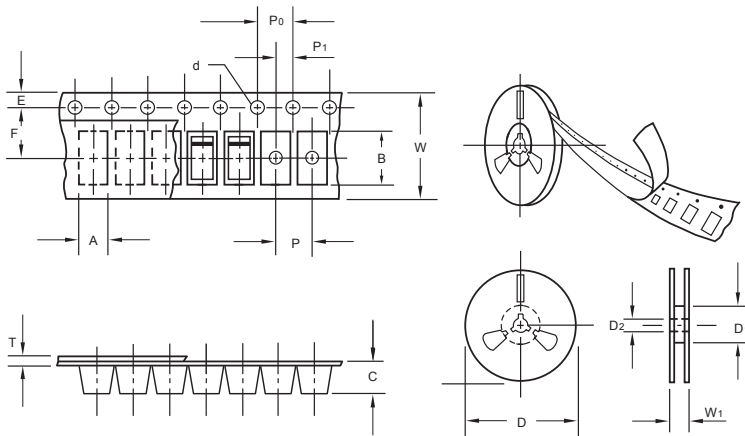

unit:mm

Item	Symbol	Tolerance	SOD-123FL
Carrier width	A	0.1	2.1
Carrier length	B	0.1	4.0
Carrier depth	C	0.1	1.60
Sprocket hole	d	0.05	1.55
7" Reel outside diameter	D	2.0	178.00
7" Reel inner diameter	D1	min	50.0
Feed hole diameter	D2	0.5	13.00
Sprocket hole position	E	0.1	1.75
Punch hole position	F	0.1	3.50
Punch hole pitch	P	0.1	4.00
Sprocket hole pitch	P0	0.1	4.00
Embossment center	P1	0.1	2.00
Overall tape thickness	T	0.1	0.25
Tape width	W	0.3	8.15
Reel width	W1	1.0	10.5

Note: Devices are packed in accordance with EIA standard RS-481-A and specifications listed above.

## Reel packing

PACKAGE	REEL SIZE	REEL (pcs)	COMPONENT SPACING (m/m)	BOX (pcs)	INNER BOX (m/m)	REEL DIA, (m/m)	CARTON SIZE (m/m)	CARTON (pcs)	APPROX. GROSS WEIGHT (kg)
SOD-123FL	7"	3,000	4.0	45,000	210*208*203	178	430*430*235	180,000	9.0

## Suggested Pad Layout

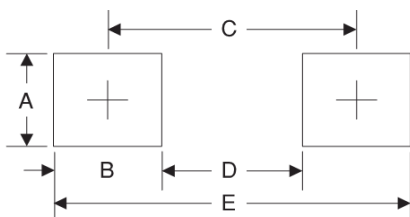

Symbol	Unit (mm)	Unit (inch)
A	1.2	0.047
B	1.2	0.047
C	3.2	0.126
D	2	0.079
E	4.4	0.173